

# Introduction to Neutron Scattering

J.T.Haraldsen

*Department of Physics and Astronomy, University of Tennessee, Knoxville, TN 37996*

Neutron scattering is a powerful and direct means for investigating the vibrational, magnetic, and structural properties of materials. In this paper, I will present a brief introduction to neutron scattering. I will discuss why neutrons are important, how and where you get neutrons, and types of neutron scattering. This paper is meant as brief introduction into an interesting field of science that is helping pave the way in the understanding of new materials and theory.

## I. PROPERTIES OF A NEUTRON

The neutron is one of the fundamental particles in nature. It consists of two down quarks and an up quark.<sup>1</sup> This combination of quarks leaves the neutron with no net charge, spin of 1/2, and a magnetic moment.<sup>2-4</sup> It is this neutrality that makes the neutron very useful in condensed matter physics. The neutrons energy can be defined by

$$E = k_B T = \frac{h^2}{2m\lambda^2} = h\nu. \quad (1)$$

For the neutron to be useful, we have to take advantage of the neutrons wave-like nature using the de Broglie relationship of

$$\lambda = \frac{h}{p} = \frac{h}{mv}, \quad (2)$$

where the neutrons wavelength is inversely proportional to the momentum and therefore inversely proportional to its velocity.<sup>2</sup> The nature of the neutron allows it to have a wavelength and energy that is ideal for material analysis. This means its wavelength can be easily tuned to by its velocity. Since the wavelength of neutron is a few Angstroms, it is possible for the neutron to be used to easily investigate the atomic length scales. For example, a neutron with 81.8 meV of energy will be travelling  $\approx 4000$  m/s and have a wavelength of 1 Å. By cooling down the neutrons, the wavelength can be increased to about 9Å. This makes it possible to investigate more

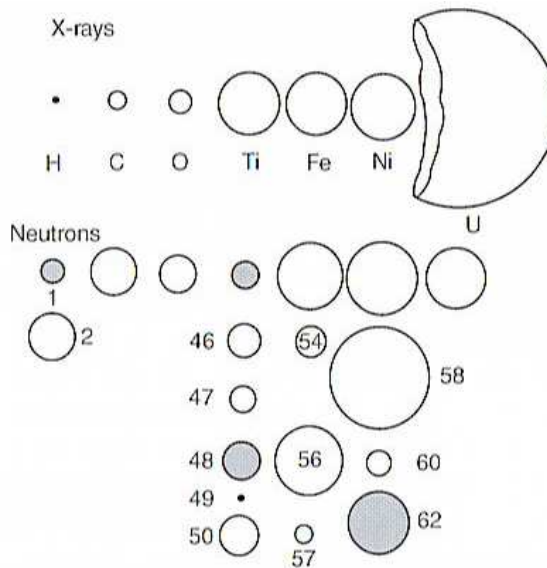

FIG. 1: Schematic representation of the scattering cross-sections of elements for X-rays and neutrons. The radii of the circle are proportional to the scattering amplitudes for the elements.<sup>6</sup>

micro-structures.

The main question that is asked about neutrons is, “why use neutrons? You already have x-ray scattering, why are neutrons important?” The use of neutrons allows for the investigation of the static (structural) and the dynamic (vibrational and magnetic) properties of materials in all fields. When combined with x-ray scattering the ability to cover a large range of momentum and energy transfers can be examined. The properties of the neutron bring about some very important consequences that make the neutron a valuable tool in in the science community.

An advantage that neutrons have is they do not have any charge, this means that the neutron will mainly interact with the atomic nucleus and not the electron cloud,

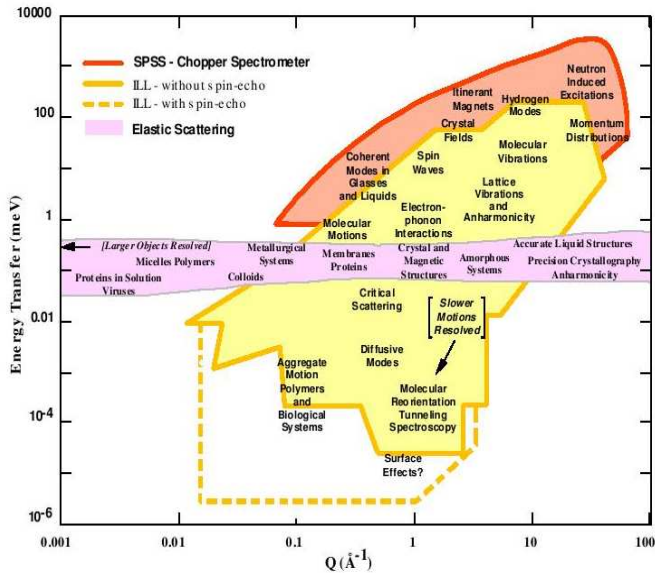

FIG. 2: The various applications of neutron scattering in terms of momentum and energy transfers.<sup>5</sup>

making the response of the neutron from lighter elements like hydrogen, deuterium, and oxygen much greater than the response from x-rays.<sup>5</sup> The ability for neutrons to penetrate the nucleus allows for the neutrons to discriminate between atoms of comparable atomic number, as well as, distinguish between isotopes of atoms as well. Figure 1 shows a schematic representation of the scattering cross-sections for x-rays and neutrons. Due to the interaction of x-ray and the electrons, the X-ray cross-sections increase as function of the atomic number.<sup>6</sup> However, neutrons do not interact with the electrons and therefore the cross-sections for lighter elements that are normally hard to see with X-rays are clearly observed by neutrons. The most popular example is that of hydrogen and deuterium. The scattering cross-section for hydrogen is extremely large, unlike in X-ray scattering, but the simple change to deuterium makes a dramatic change to the neutron scattering cross-section.<sup>2</sup> This means that neutrons can be used to determine the static properties of a material (the atomic position, structure, and length) through the use to neutron diffraction and small-angle neutron scattering.

Due to the lower energy of the neutron compared to

x-rays, neutrons can also be used to investigate the more dynamic properties of a material. The low energy vibrational and magnetic excitations of materials can be examined by looking at the different energy and momentum transfers of neutrons.<sup>5</sup> With the use of neutrons, all vibrational modes in a material have the ability to be active, since neutrons are subject to the optical selection rules. The large penetration depth of neutrons, caused by the neutrons weakly interacting nature and neutrality, means that the bulk properties of materials can be studied, as well as, the ability to “easily” investigate materials under conditions like very low or very high temperatures, high pressures, high magnetic or electric fields and so on.

The previous points have focused mainly on the neutrality of the neutron, but the neutron also carries a magnetic moment.<sup>5</sup> This allows the neutron to be an excellent microscopic probe for the magnetic structure and magnetic excitations within materials.

Overall, neutrons can be used to probe various areas of condensed matter physics. In figure 2, the different applications of neutron scattering are shown on scales of energy and momentum transfer. It is possible to examine areas from crystal structure to molecular vibrations to spin waves and magnetic interactions. Making neutron scattering one of the most versatile and useful probes. When combined with other experimental techniques such as x-ray scattering, electron scattering, magnetic susceptibility, and spectroscopy, condensed matter sciences can gain a complete picture of a materials properties and structure.

## II. SOURCES OF NEUTRONS

The properties of neutrons are great, but they are not worth anything unless you can produce them easily for the use of experimenters. In this section, we will look at the ways neutrons are produced and where this is being done.

Neutrons can be found everywhere in nature. Since

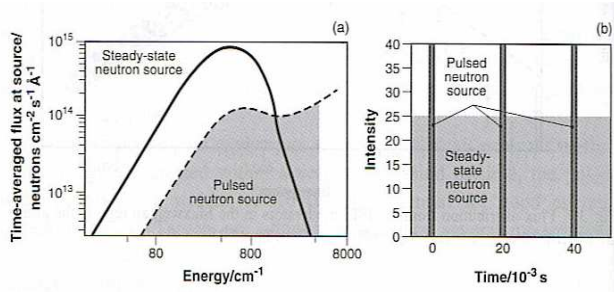

FIG. 3: Comparisons of the a) time-averaged flux versus energy and b) intensity versus time for the reactor source and spallation source.<sup>7</sup>

they are a large component to the stability of the transition and heavy metal atoms.<sup>4</sup> The only drawback is isolating them. To do this, one needs to be able to energetically eject neutrons from the nucleus. Therefore, the way you get them is by breaking the atoms up and releasing neutrons. This can be done through the use of either a nuclear reactor or a spallation source. Both are very effective, but have two different outcomes.

The nuclear reactor will produce neutrons in a continuous flow. This provides experimenters with a moderate flux of neutrons at a constant intensity.<sup>7</sup> The spallation source provides short period pulses of neutrons. This gives the experimenters a much higher intensity and higher flux of neutrons in short millisecond pulses. The higher flux and intensity of the spallation sources sounds like the better, but when averaged over time the spallation source has a lower time-averaged flux than that of the reactor sources (as shown in fig. 3).

### A. Reactor Source

The reactor source is a research grade nuclear reactor where the fission of uranium produces a continuous flow of neutrons. The research reactor is fundamentally different than the nuclear power reactors that people read about. The overall physics is the same in that they use a chain reaction of the fission of uranium, but the purpose of the research reactor is the simple production of neutrons, not the production of heat.<sup>7</sup> Heat production

(which is essential in power plants) is not desired in the research reactor, because the heat creates thermal fluctuations in the experiment and hinders the analysis of data. It is because of the heat limit, that these reactors are limited in the overall flux of neutrons produced.<sup>7</sup> In figure 4, it is clear that the effective neutron flux is limited to about  $10^{15}$  neutrons per  $\text{cm}^2 \text{s}^{-1}$ . Therefore, in order for research reactors to evolve to higher flux, they have to overcome this thermal barrier. However, another source is already surpassing the reactor in flux. This is the spallation source.

### B. Spallation Source

The spallation sources run off a completely different physics than that of a reactor. In a spallation, a neutron rich, heavy metal target is bombarded with pulses of protons. As the protons collide with the target, this creates a cascade effect that produces a large number of neutrons per pulse.<sup>7</sup> Therefore creating a large flux over the time of the pulse. The cascade of neutrons are only produced during the pulse and therefore does not allow for a continuous flow of neutrons. However, as shown in figure 3, the time-average flux is similar to that of reactors. In figure 5, a graphical representation of

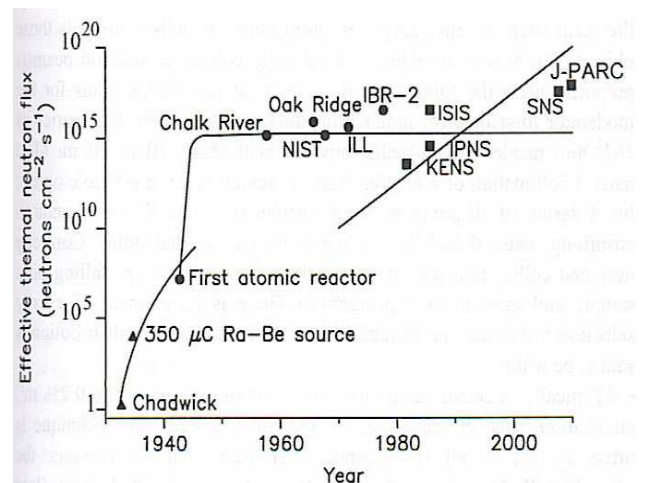

FIG. 4: The evolution of neutron flux over the past century. Black circles are reactor sources and black squares are spallation sources.<sup>7</sup>

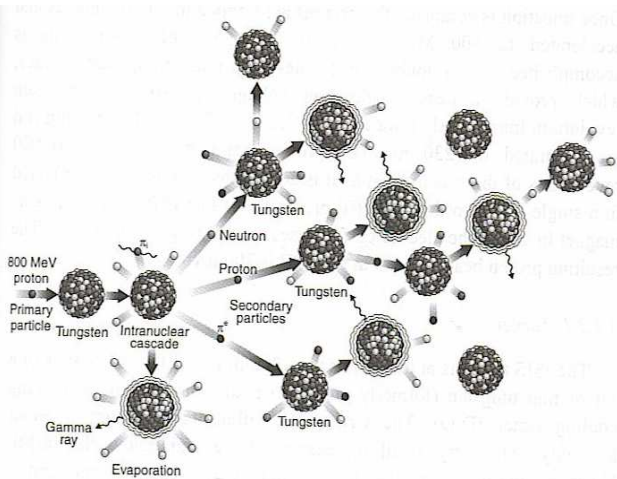

FIG. 5: A graphical representation of a spallation source cascade for the production of neutrons.

a neutron cascade from the tungsten target at ISIS is shown.<sup>7</sup> The target can be any heavy metal. At the SNS, the target is a mercury target.

The spallation source is also different from a reactor in that it only produces modest heat when compared to the steady state reactors. The time averaged heat production at a spallation source is about 160 kW, where as the equivalent reactor power would be 16000MW.<sup>7</sup> This gives spallation sources a larger area to grow in overall flux, whereas reactor sources have to worry about the heat limit.

### C. Locations of Neutron Sources

Over the past century, many countries have worked together to provide different reactor and spallation sources for the science community. The most current source being constructed is in Oak Ridge Tennessee at the Oak Ridge National Laboratory (ORNL). This new source is the Spallation Neutron Source (SNS). The construction of the SNS is hoped to compliment the High Flux Isotope Reactor (HFIR) already at ORNL. Figure 6 shows the layout of the HFIR facility at ORNL with the proposed upgrades that are currently being constructed.<sup>8</sup> By having both sources in a close proximity to each other,

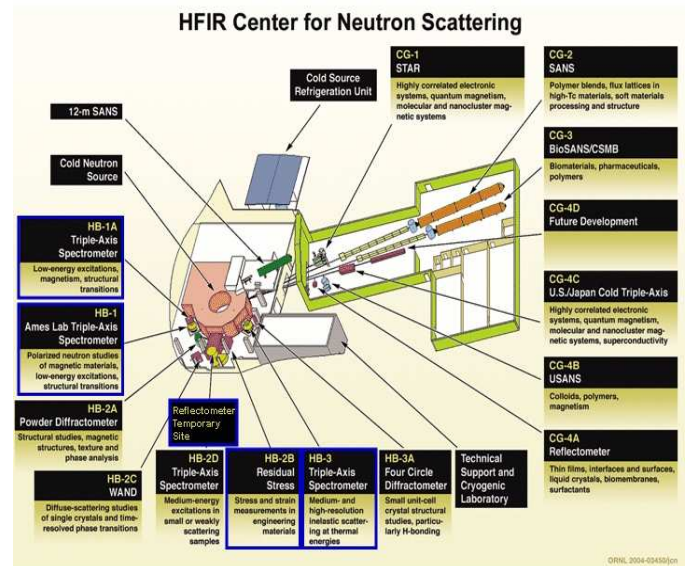

FIG. 6: High Flux Isotope Reactor at Oak Ridge National Laboratory in Oak Ridge, Tennessee. Shown in the figure are the various current and upgraded instruments.<sup>8</sup>

scientist will be able to take advantage of both source without much travel. Making Oak Ridge and East Tennessee a neutron scattering hub of the world. Table I is a list of some of the other sources around the world that have and continue to help the neutron sciences grow.<sup>7</sup>

Over the past century, many different sources have been constructed. Figure 4 shows the flux output of certain sources over the past century.<sup>7</sup> It is clear that the future of neutron scattering lies with the spallation sources. Mainly due to the heat-load being less in the spallation sources, but also from the political and environmental aspects of the spallation source. Being that the spallation source does not require fissile material and less active waste is produced, they tend to be the more favorable endeavor.

## III. NEUTRON SCATTERING

Once the neutrons are produced, you have about 9 mins before they decay.<sup>1</sup> Therefore, it is imperative that experimenters act quick and use them. The main question is how can this be done.

The science of neutron scattering can be broken

TABLE I: Some of the Operating and Planned Reactor and Spallation Sources.<sup>7</sup>

Name	Institution	Location	Startup Date	Source Type
BRR	Budapest Neutron Center	Hungary	1959	Reactor
R-2	Neutron Research Lab (NFL)	Sweden	1960	Reactor
HFIR	Oak Ridge National Laboratory (ORNL)	USA	1966	Reactor
NBSR	National Institute of Standards and Technology (NIST)	USA	1969	Reactor
HFR	Institute Laue Langevin (ILL)	France	1972	Reactor
BER-II	Hahn-Meitner Institute	Germany	1973	Reactor
MARIE	Institute of Atomic Energy	Poland	1974	Reactor
IPNS	Argonne National Laboratory	USA	1981	Spallation
IBR-2	Joint Institute of Neutron Research (JINR)	Russia	1984	Spallation
DHRUVA	Bhabha Atomic Research Center	India	1985	Reactor
LANSCE	Los Alamos National Laboratory	USA	1985	Spallation
ISIS	Rutherford-Appleton Laboratory	England	1985	Spallation
JRR3M	Japanese Atomic Energy Research Institute (JAERI)	Japan	1990	Reactor
SNS	Oak Ridge National Laboratory (ORNL)	USA	UC <sup>a</sup>	Spallation
FRM-II	Technical University of Munich	Germany	WA <sup>b</sup>	Reactor
ESS	European Science Foundation	Europe	UC <sup>a</sup>	Spallation

<sup>a</sup>UC stands for Under Construction <sup>b</sup>WA stands for Waiting for Approval

into two main areas; elastic scattering and inelastic scattering.<sup>2</sup> Both areas are very useful and important, but they are fundamentally different. As a neutron scatters from a sample, the two main quantities that can be examined are the change in momentum and the change in energy. These are shown, because of conservation of momentum and energy, as

$$\mathbf{Q} = \mathbf{k}_i - \mathbf{k}_f \quad (3)$$

and

$$\omega = \frac{1}{\hbar}(E_i - E_f) = \frac{\hbar}{2m}(\mathbf{k}_i^2 - \mathbf{k}_f^2), \quad (4)$$

where  $\mathbf{k}_i$  and  $\mathbf{k}_f$  are the initial and final momenta and  $E_i$  and  $E_f$  is the initial and final energies of the neutron. The difference between inelastic and elastic neutron scattering is whether or not the energy of the neutron is altered. This can be described pictorially in figure 7.

The intensity of the energy and momentum transfer of a neutron can be examined in detail by experiment by

monitoring the initial and final states of the neutrons. As neutrons are scattered from a sample, they are detected at specific angles and intensities related to the atoms and interactions for which they scatter. Figure 8 shows the geometry of scattering neutrons from a sample and how they form a total flux through a solid angle,  $d\Omega$ .<sup>2</sup> The result of each scattering system can be measured by the quantity known as the total differential cross-section, which is given by

$$\left( \frac{d^2\sigma}{d\Omega dE} \right)_{k_0 \rightarrow k_1} = \frac{1}{N} \frac{k_f}{k_i} \left( \frac{m}{2\pi\hbar^2} \right)^2 \sum p_i p_f \sum | \langle \mathbf{k}_f | V | \mathbf{k}_i \rangle |^2 \delta(E + E_i - E_f), \quad (5)$$

where  $N$  is the number of nuclei,  $k$  is the momentum,  $p$  is the state probability, and the sums are over all states and polarizations. This is called the master formula for which the basis of all experimental interpretation is derived.<sup>6</sup> The master formula can be expressed, with the use of some



tricks, as

$$\left( \frac{d^2\sigma}{d\Omega dE} \right)_{k_0 \rightarrow k_1} = N \frac{k_f}{k_i} b^2 S(\mathbf{Q}, \omega) \quad (6)$$

where  $b$  is the scattering length and  $S(\mathbf{Q}, \omega)$  is the scattering function or structure factor.<sup>10</sup> This structure factor is given by

$$S(\mathbf{Q}, \omega) = \frac{1}{2\pi\hbar} \int G(\mathbf{r}, t) e^{i(\mathbf{Q}\cdot\mathbf{r} - \omega t)} d\mathbf{r} dt, \quad (7)$$

where  $G(\mathbf{r}, t)$  is the time-dependent pair correlation function given by<sup>10</sup>

$$G(\mathbf{r}, t) = \left( \frac{1}{2\pi} \right)^3 \frac{1}{N} \int \sum_{jj'} e^{i\mathbf{Q}\cdot\mathbf{r}} \langle e^{-i\mathbf{Q}\cdot\mathbf{r}_{j'}(0)} e^{i\mathbf{Q}\cdot\mathbf{r}_j(t)} \rangle d\mathbf{Q}, \quad (8)$$

This shows the structure factor is a Fourier transform of the pair-correlation function.<sup>2</sup> Therefore,  $S(Q, \omega)$  is a measure of the intensity of the scattered neutrons, and is dependent on the distinct positions of the atoms and molecules in the material. In most neutron scatter-

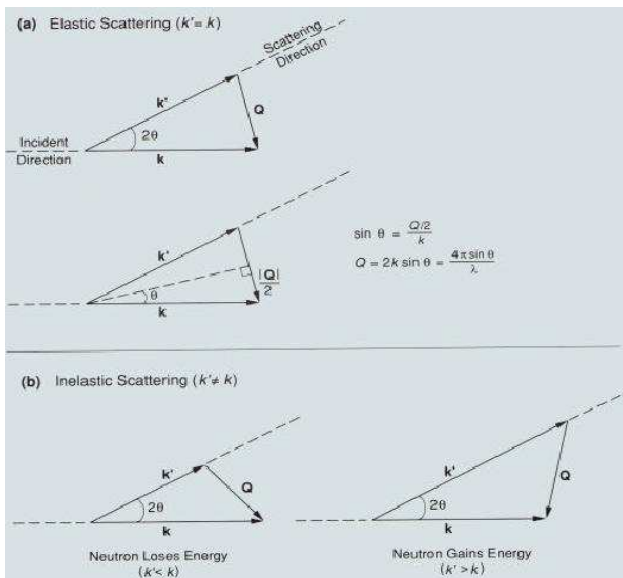

FIG. 7: Graphical description of momentum and energy transfer for an a) elastic scattering and b) inelastic scattering.<sup>9</sup>

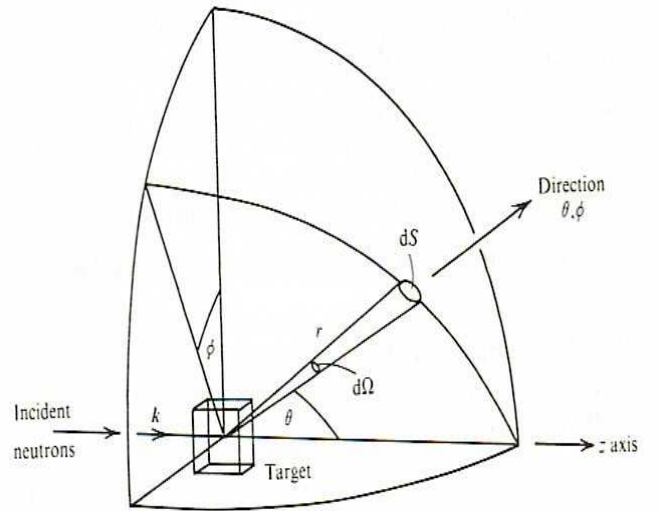

FIG. 8: The basic geometry of a neutron scattering experiment.<sup>2</sup>

ing experiments,  $S(Q, \omega)$  is measured and examined and the pair-correlation function can be found through the Fourier transform.

In Figure 9, we can see how the energies of some excitations relate to  $S(Q, \omega)$  over the electromagnetic spectrum.<sup>7</sup> Here, it is shown that the  $S(Q, \omega)$  can be used to investigate the elastic band region (energy transfer  $\approx 0$ ), but also the inelastic region (energy transfer  $> 0$ ) that contain vibrational and magnetic excitations, as well as other material properties.

### A. Elastic Neutron Scattering

Elastic neutron scattering (ENS) is the scattering of neutrons without the loss of energy. All that is determined is the transfer of momentum or angle of scattering. ENS measurements typically include neutron diffraction and small-angle scattering.<sup>9</sup> These are techniques for which atomic, molecular, and lattice spacings are determined. By investigating the structure factor as a function of momentum transfer, one can determine the molecular or lattice structure of a material through a Fourier analysis. Figure 10 shows how elastic neutron

scattering (neutron diffraction and small-angle neutron scattering) fits into the picture of understanding the total structure of a material.<sup>9</sup> Neutron scattering can be used to resolve structure from crystallographic atomic spacing to polymer microstructures. Structures like viruses and bacteria are still just outside the range of neutron scattering.

### 1. Neutron Diffraction

In neutron diffraction, the determination of the atomic spacings allows for experimentalists to construct the atomic structure of a material. Since the neutron is not effected about the electron charge, it is able to penetrate all the way to the nucleus, providing information about the structure of the material. Figure 11 shows the neutron diffraction pattern for the material of  $Y_2Ba_4Cu_7O_{15}$ .<sup>3</sup> From the change in momentum (or angle) and the intensity of of the peaks, the structure of  $Y_2Ba_4Cu_7O_{15}$  can be determined through a Fourier transform of the spectrum. This relates the momentum with the precise positions of the atoms.

Neutron diffraction can also be used to examine the

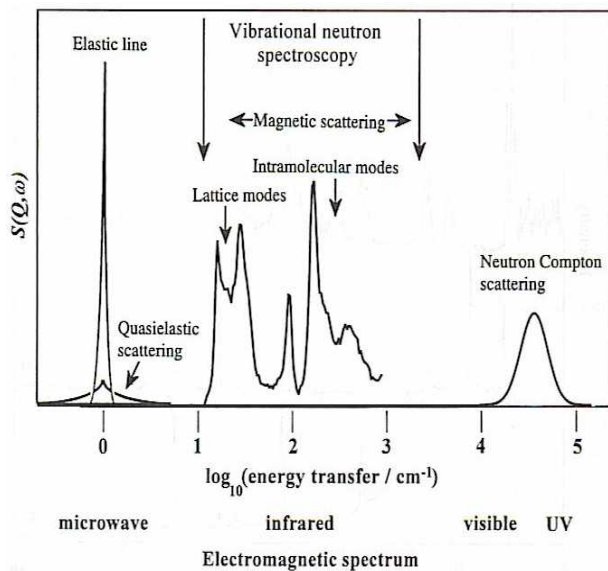

FIG. 9: The neutron scattering intensity as a function of energy transfer. Highlighting some of the excitations that can be observed through the electromagnetic spectrum.

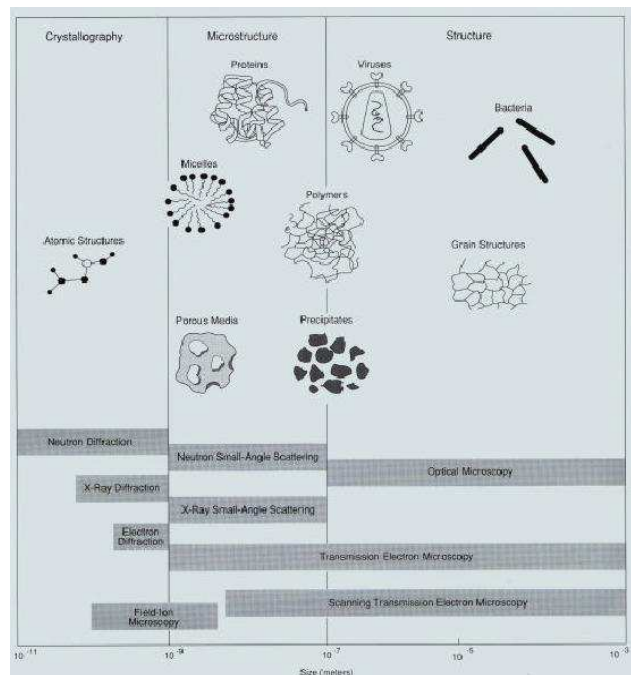

FIG. 10: The range of neutron scattering to resolve nano- and micro-structures.

more than just the atomic positions. It can be use to examine the electron densities for a complete understanding of the d-orbital interactions within many materials with applied field. In 2003, Wang *et al.* published a letter in the Physical Review Letters about their work on understanding the electron population in bilayered manganites,<sup>12</sup> which can help to determine a complete picture of the orbital interactions in these materials.

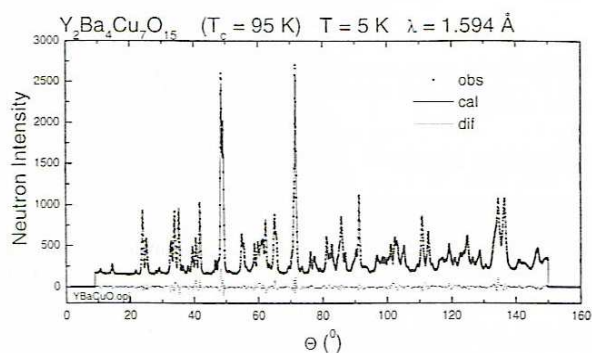

FIG. 11: Neutron diffraction pattern for  $Y_2Ba_4Cu_7O_{15}$ .<sup>3</sup> This data helps clarify the atomic structure of the material.

## 2. Small-Angle Scattering

Small-angle scattering is typically used for the determination and isolation of larger, more complex molecules like polymers or DNA (length scales of 1 - 300 nm).<sup>9</sup> Due to the inverse relationship of momentum to position, examining the smaller the momentum transfer or angle scattering the more information you gain about the larger structures in the material. This is particularly useful in determining the large structure of materials in liquid and polymer samples. Since  $S(\mathbf{Q}, \omega)$  is related to  $G(\mathbf{r}, t)$ , it is possible to examine the structure of materials through the propagation of time and examine the evolution of large structures. This is done in a similar manner to that of neutron diffraction.

The study of DNA and proteins has been particularly interested in small-angle neutron scattering. As presented in a review article in 1988, x-ray and neutron scattering are two important tools that compliment each other in the studying the structure properties of proteins.<sup>13</sup>

### B. Inelastic Neutron Scattering

Inelastic neutron scattering (INS) becomes important when you want to investigate dynamic properties like vibrational and magnetic excitations where neutron energy is changed.<sup>11</sup> Therefore, neutrons can now lose some energy to excite phonons and magnetic excitations. These can be examined as the complete picture of the structure factor,  $S(\mathbf{Q}, \omega)$ , as function of energy and momentum. This is because each individual energy excitation has a distinct energy and momentum transfer, which is dependent on atomic position and cross section, that acts like a finger print to that specific material. Figure 12 shows the phonons and magnetic excitations of  $\text{Na}_3\text{RuO}_4$ .<sup>14</sup> The phonons are shown on the right-hand side whereas the magnetic excitations are on smaller on the bottom left. Through an analysis of the phonons and magnetic exci-

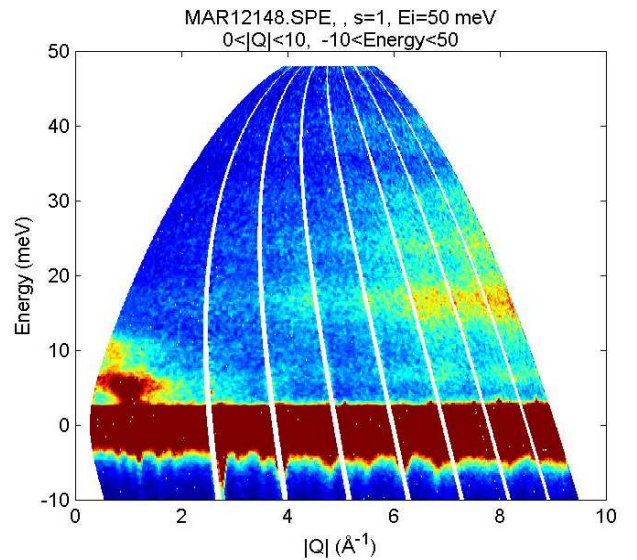

FIG. 12: Recent unpublished inelastic neutron scattering data for  $\text{Na}_3\text{RuO}_4$ .<sup>14</sup> Shown are the low energy magnetic and phonon excitations.

tations, scientists can gain a complete understanding of the molecular structure of  $\text{Na}_3\text{RuO}_4$ .

#### 1. Phonons

The phonons of a material can be completely described by INS since neutrons do not have the constraints of optical selection rules. The neutron intensity of the phonons are directly related to the phonon polarization vectors. This makes it possible to understand all the motions of the lattice and atoms within a material.<sup>7</sup> From figure 12, it is apparent that phonons are usually much larger in size and intensity than are magnetic excitations.

#### 2. Magnetic Excitations

Due to the spin and magnetic moment of the neutron, inelastic neutron scattering is ideal for determining the magnetic structure and excitations for magnetic materials. Magnetic systems can be described as either finite magnetic clusters or extended magnetically ordered systems. Finite clusters have discrete energy excitations with a momentum dependence.<sup>6</sup> Unlike phonons, mag-



netic excitations show a distinct effect with change in temperature due to thermal excitations. Therefore, magnetic excitation, which are clearly present at low temperature, decrease in size and seem to disappear as temperature is risen.<sup>15</sup> Also, the magnetic excitations have a magnetic form factor that decreases the intensity as momentum transfer increases. In figure 12, it is clear that the intensity of the 5 meV excitation drops off after about  $1.5 \text{ \AA}^{-1}$ . The momentum dependence of magnetic clusters is dependent not only on the strength of the interaction of superexchange pathway, but the distance between the magnetic ions as well. This is most apparent in the example of  $\text{VODPO}_4 \cdot \frac{1}{2}\text{D}_2\text{O}$ . This is a magnetic spin dimer consisting of two spin  $1/2$  vanadium ions. The structure of  $\text{VODPO}_4 \cdot \frac{1}{2}\text{D}_2\text{O}$  is shown in figure 13. Here it was assumed that the magnetic dimer was the shorter P1 superexchange pathway. However, through the use of inelastic neutron scattering, it is possible to fit the Q-dependence of the intensity and determine the actual ionic separation. The data from the inelastic

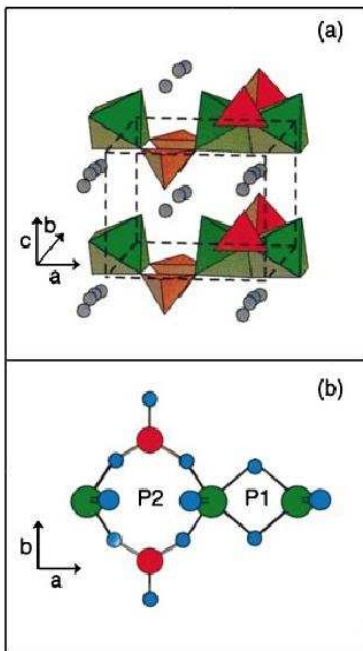

FIG. 13: Atomic structure for  $\text{VODPO}_4 \cdot \frac{1}{2}\text{D}_2\text{O}$ . The designations of P1 and P2 denote the separation between vanadium ions (green). These are the short and long dimers, respectively

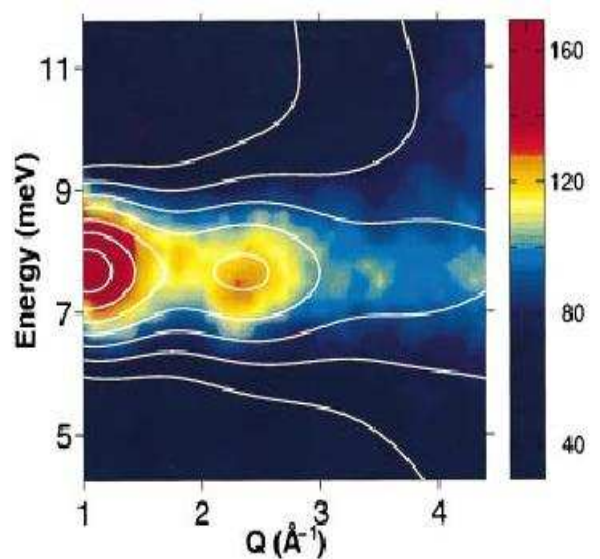

FIG. 14: The inelastic neutron scattering data for  $\text{VODPO}_4 \cdot \frac{1}{2}\text{D}_2\text{O}$ . The data has been fit with a Heisenberg spin dimer model. This model helped clarify which dimer is the dominant superexchange pathway.

neutron scattering is shown in figure 14. After the fitting, it was apparent that the actual separation was that of the P2 supersuperexchange pathway.<sup>16</sup> This is a great example of the power of inelastic neutron scattering in investigating not only the magnetic excitations, but the actual magnetic structure.

In extended systems, the discrete energy excitations begin having a Q-dependence. This creates the presence of spin waves or magnons. This is created by the propagation of a spin excitation that travels through the extended magnetic structure. Figure 15 shows how the spin excitation can propagate forming a spin wave.<sup>17</sup>

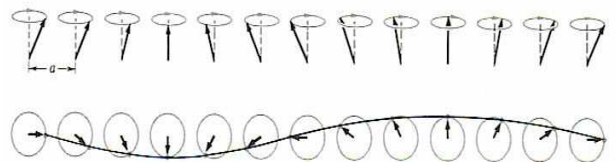

FIG. 15: A spin wave on a line of spins.<sup>17</sup>

#### IV. CONCLUSION

In summary, the properties the neutron allow it to be useful in a variety of experimental techniques. The neutrality of the neutron allowed it to penetrate the electron cloud and interact directly with the nucleus of the atoms. Neutrons useful in determining the atomic crystallographic structure of materials through neutron

diffraction and small-angle scattering. Investigations into inelastic neutron scattering allow for examination of the vibrational and magnetic excitations of materials. Through the examples shown above, neutron scattering is a versatile and excellent microscopic probe for condensed matter physics.

- 
- <sup>1</sup> D. Griffith, *Introduction to Elementary Particles* (Wiley, 1987)
- <sup>2</sup> G.L.Squires, *Introduction to the Theory of Thermal Neutron Scattering* (Dover, 1996).
- <sup>3</sup> A. Furrer, *Frontiers of Neutron Scattering* (World Scientific, 2000).
- <sup>4</sup> N. W. Ashcroft and N. D. Mermin *Solid State Physics* (Thompson Learning, 1976)
- <sup>5</sup> G. Shirane, S. M. Shapiro, and J. M. Tranquada, *Neutron Scattering with a Triple-Axis Spectrometer* (Cambridge University Press, 2002).
- <sup>6</sup> T. Chatterji, *Neutron Scattering from Magnetic Materials* (World Scientific, 2005).
- <sup>7</sup> P. Mitchell, S.F. Parker, A.J. Ramirez-Cuesta, and J. Tomkinson, *Vibrational Spectroscopy with Neutrons: With Applications in Chemistry, Biology, Materials Science, and Catalysis* (World Scientific, 2005).
- <sup>8</sup> <http://neutrons.ornl.gov/>
- <sup>9</sup> R. Pynn, *Neutron Scattering: A Primer* (Los Alamos Science, 1989).
- <sup>10</sup> L. van Hove, Phys. Rev. 95, 249 (1954).
- <sup>11</sup> Y. A. Alexandrov, *Fundamental Properties of the Neutron* (Clarendon Press, 1992).
- <sup>12</sup> F. Wang, A. Gukasov, F. Moussa, M. Hennion, M. Apostu, R. Suryanarayanan, and A. Revcolevschi, Phys. Rev. Lett. 91, 047204 (2003)
- <sup>13</sup> S.J. Perkins, Biochem. J. 254, 313 (1998)
- <sup>14</sup> M. B. Stone, M. D. Lumsden, J.T. Haraldsen, and T. Barnes, Unpublished Data.
- <sup>15</sup> O. Kahn, *Molecular Magnetism* (VCH Publishers, 1993).
- <sup>16</sup> D.A.Tennant, S.E.Nagler, A.W.Garrett, T.Barnes and C.C.Torardi, Phys. Rev. Lett. 78, 4998 (1997).
- <sup>17</sup> C. Kittel, *Introduction to Solid State Physics* (Wiley, 1996)